



SLIDE-PAC™ CONVEYORS

Quickly and Safely Roll Conveyors From Transport to Operation Instead of Risky Lifting



SLIDE-PAC TRANSFER CONVEYORS



SLIDE-STAC CONVEYOR STOCKPILING

Rock Face to Load Out™



SPECIFICATIONS

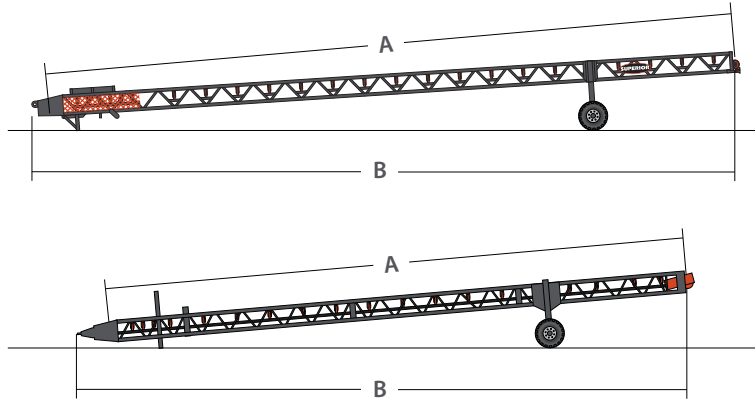

SLIDE-PAC CONVEYORS				SLIDE-STAC CONVEYORS	
OPERATING DIMENSIONS	60'	70'	80'	60'	70'
(A) Conveyor Length (m)	60'-0" (18.3)	70'-0" (21.3)	80'-0" (24.4)	60'-0" (18.3)	70'-0" (21.3)
(B) Conveyor Ground Length (m)	58'-9" (18.0) to 59'-7" (18.2)	68'-10" (21.8) to 69'-7" (21.2)	79'-1" (24.1) to 79'-7" (24.3)	56'-7" (17.2)	66'-1" (20.1)
Raised Height to Center of Pulley (m)	Varies	Varies	Varies	Varies	Varies
Lowered Height to Center of Pulley (m)	Varies	Varies	Varies	Varies	Varies

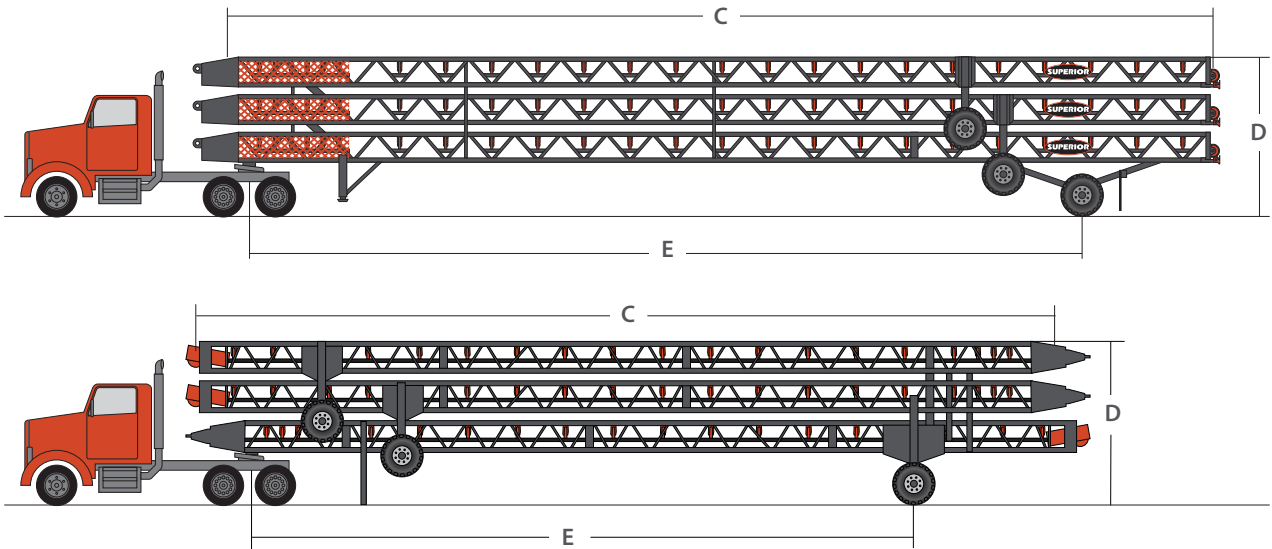

SLIDE-PAC CONVEYORS				SLIDE-STAC CONVEYORS	
TRAVEL DIMENSIONS	60'	70'	80'	60'	70'
(C) Travel Length (m)	59'-8" (18.2)	69'-8" (21.2)	79'-8" (24.2)	59'-8" (18.1)	69'-8" (21.2)
(D) Travel Height (m)	13'-6" (4.1)	13'-6" (4.1)	13'-3" (4.0)	13'-2" (4.0)	13'-5" (4.0)
Travel Width (m)	10'-1" (3.1)	9'-11" (3.0)	9'-11" (3.0)	11'-11" (3.6)	12'-0" (3.6)
(E) Kingpin to Axle (m)	44'-9" (13.6)	54'-9" (16.6)	64'-9" (20.0)	36'-11" (11.2)	49'-2" (15.0)
Weight at Axle (kg)	19,000 (8,618)	21,000 (9,525)	22,000 (9,979)	24,700 (11,203)	28,300 (12,836)
Weight at Kingpin (kg)	10,000 (4,535)	12,700 (5,760)	13,900 (6,304)	6,800 (3,084)	11,200 (5,080)



STACKABLE CONVEYORS

Bundle Up to 8 Conveyors in One Load for Substantial Freight Savings



Rock Face to Load Out™



OPTIONS



TOW EYE



EXTERRA SFL DUAL



MOXIE ROLLS



RECEIVING HOPPER



HINGED TAIL BEND



HAND CRANK AXLE JACKS

PORTABILITY

- » Tow Eye

OPERATION

- » 6-foot (1.8m) Discharge Support
- » Telescoping Tail Support Legs
- » Hinged Tail Bend

MAINTENANCE

- » Exterra® Primary Belt Cleaner
- » Moxie® Rolls
- » Urathon® Return Rolls
- » Impact Rolls
- » Radial Receiving Hopper

ENVIRONMENT

- » Epoxy Paint
- » Galvanized Paint

OTHER

- » Belt Scale

STACKABLE PLUS

- » Heavier Truss
- » Anchor Pivot Plate
- » Tow Eye
- » Manual Raise Undercarriage
- » 9-foot (2.7m) Hinged Tail Bend
- » Hand Crank Axle Jacks

SPECIFICATIONS

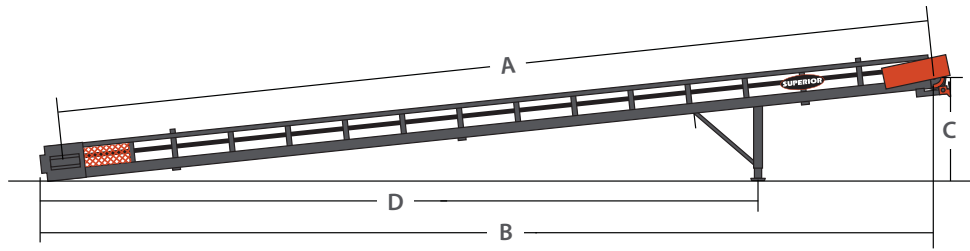

STACKABLE	50'	60'
(A) Conveyor Length (m)	50'-0" (15.2)	60'-0" (18.3)
(B) Conveyor Ground Length (m)	48'-8" (14.8)	59'-8" (18.1)
(C) Raised Height to Center of Pulley (m)	Up to 17'-11" (5.5)	Up to 21'-0" (6.4)
Lowered Height to Center of Pulley (m)	12'-5" (3.8)	12'-5" (3.8)
(D) Anchor Pivot to Center of Axle (m)	25'-5" (7.8)	31'-2" (9.5)

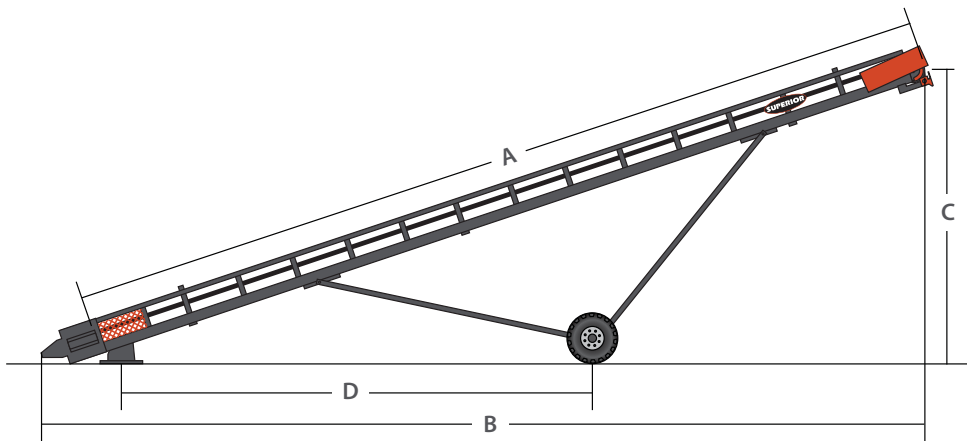

STACKABLE PLUS	50' CONVEYOR	60' CONVEYOR
(A) Conveyor Length (m)	50'-0" (15.2)	60'-0" (18.3)
(B) Conveyor Ground Length (m)	49'-2" (15.0)	57'-3" (17.4)
(C) Raised Height to Center of Pulley (m)	16'-7" (5.0)	19'-4" (5.8)
Lowered Height to Center of Pulley (m)	9'-0" (2.7)	7'-11" (2.4)
(D) Anchor Pivot to Center of Axle (m)	26'-10" (8.2)	32'-9" (10.0)
Maximum Stockpile Height - Feet (M)	18'-6" (5.7)	21'-6" (6.6)
Maximum Stockpile Capacity - Cubic Yards (M ₃)	430 (328)	680 (519)
18° Straight Incline - Tons (MT)	580 (526)	920 (834)

SPECIFICATIONS CONTINUED

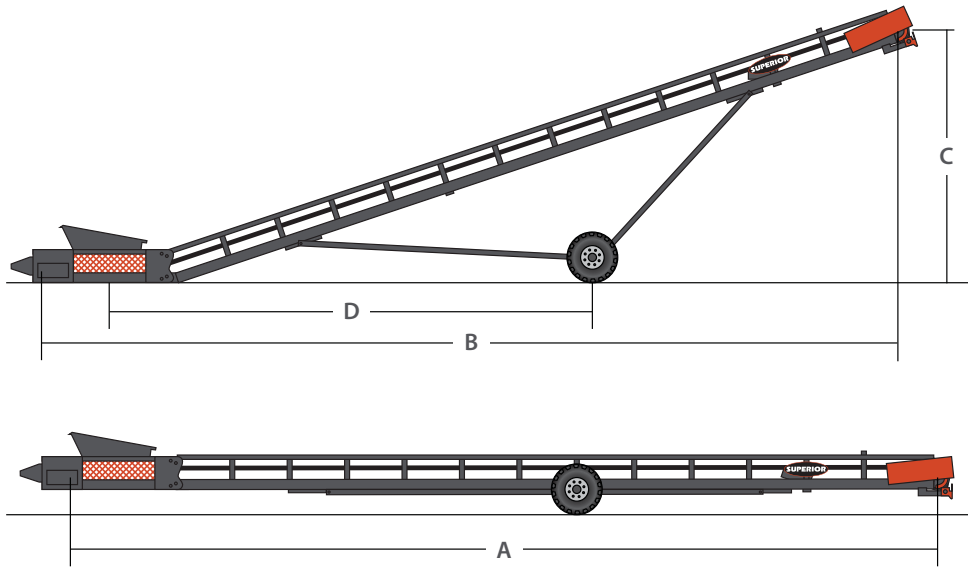

STACKABLE PLUS WITH BEND	50' CONVEYOR	60' CONVEYOR
(A) Conveyor Length - Center of Pulley to Center of Pulley (m)	50'-0" (15.2)	60'-0" (18.3)
(B) Conveyor Ground Length (m)	47'-5" (14.4)	57'-0" (17.3)
(C) Raised Height to Center of Pulley (m)	15'-5" (4.7)	18'-6" (5.6)
Lowered Height to Center of Pulley (m)	4'-6" (1.3)	4'-7" (1.3)
(D) Anchor Pivot to Center of Axle (m)	28'-2" (8.6)	38'-10" (11.8)
Maximum Stockpile Height - Feet (M)	19'-6" (6.0)	22'-6" (6.9)
Maximum Stockpile Capacity - Cubic Yards (M ₃)	490 (374)	780 (596)
19° Straight Incline - Tons (MT)	660 (598)	1,100 (997)



JUMP CONVEYORS

Workhorse, Custom-Engineered Conveyors Easily Shift Into Operation



Rock Face to Load Out™



OPTIONS

OPERATION

- » Radial Receiving Hopper
- » 6-foot (1.8m) Discharge Support
- » Anchor Pivot Plate
- » Belt Scale

MAINTENANCE

- » Exterra® Primary Belt Cleaner
- » Moxie® Rolls
- » Urathon® Return Rolls
- » Impact Rolls
- » Auto Greaser

MOBILITY

- » Power Travel
- » Strut Axle
- » Landing Gear
- » Fifth Wheel Hitch
- » Lights and Brakes
- » Tow Eye

SPECIFICATIONS

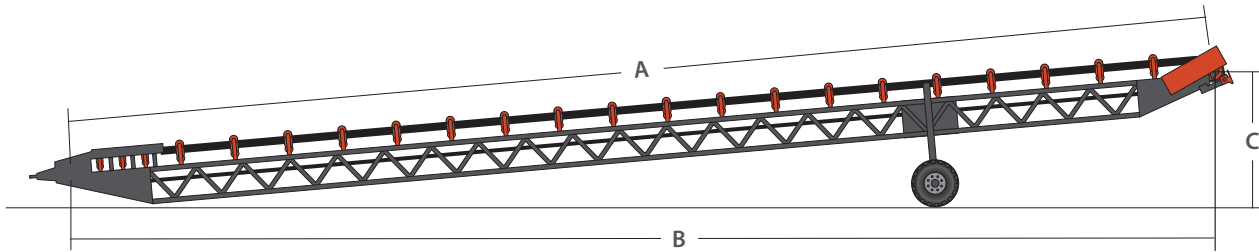

OPERATING DIMENSIONS	40'	50'	60'	80'	100'
(A) Conveyor Length (m)	40'-0" (12.1)	50'-0" (15.2)	58'-9" (17.9)	80'-0" (24.4)	100'-0" (30.5)
(B) Conveyor Ground Length (m)	40'-3" (12.2)	45'-10" (14.0)	49'-4" (15.0)	79'-9" (24.4)	94'-9" (28.9)
(C) Raised Height to Center of Pulley (m)	11'-7" (3.5)	12'-4" (3.7)	13'-7" (4.1)	12'-2" (3.7)	11'-11" (3.6)
Lowered Height to Center of Pulley (m)	7'-4" (2.2)	7'-10" (2.3)	6'-11" (2.1)	6'-10" (2.0)	7'-9" (2.3)

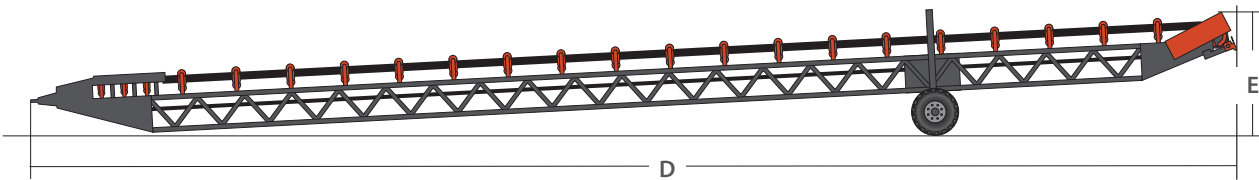

TRAVEL DIMENSIONS	40'	50'	60'	80'	100'
(D) Travel Length - 36" Belt Width (m)	44'-8" (13.6)	54'-9" (16.7)	64'-9" (19.8)	84'-9" (25.9)	71'-6" (21.7)
(E) Travel Height - 36" Belt Width (m)	8'-11" (2.7)	8'-10" (2.6)	9'-4" (2.8)	9'-5" (2.8)	14'-1" (4.2)
Travel Width - 36" Belt Width (m)	8'-6" (2.5)	8'-0" (2.4)	9'-3" (2.8); Dual 10'-1" (3.0)	9'-1" (2.7)	11'-11" (3.6); Dual 10'-5" (3.1)
Weight at Axle - 36" Belt Width (kg)	5,186 (2,352)	4,553 (2,065)	4,700 (2,131)	7,000 (3,175)	8,700 (3,946)
Weight at Kingpin - 36" Belt Width (kg)	1,463 (663)	1,910 (866)	2,400 (1,088)	3,000 (1,360)	2,900 (1,315)